



Experience, Trust, Service

GRACO® CONTRACTOR AIRLESS SPRAY GUNS



PART NUMBERS AND SCHEMATICS GUIDE

Company Profile

Since 1944, Marco has developed a strong tradition of providing innovative and reliable products and services to the surface preparation and protective coatings industries. We are the world's premier provider of Abrasives, Blasting Equipment, Coating Equipment, Engineered Systems, Rental Equipment, Safety Equipment, Service, and Repair.

Through innovative designs and a total commitment to quality, Marco manufactures products that increase production rates, create a safer workplace, and reduce maintenance costs. Marco's industry experience, manufacturing capabilities, legendary customer service, product availability, logistics services, and technology leadership is your assurance that we deliver high quality products and services, providing the best value to you, our customer.

The Marco Difference

- **Industry Experience** – With Marco on your team, you have access to expertise which can only come from decades of industry leadership. We have organized our engineering department, production specialists, customer operations, and safety support into a “Center of Competence.” As a Marco customer, you have access to hundreds of years of cumulative experience related to your operations.
- **Manufacturing Excellence** – Marco is a U.S. based, ISO 9001:2008 certified manufacturer of equipment for the Surface Preparation and Protective Coatings industries. Marco's engineers benchmark the industry to ensure that we design and manufacture superior products that set the “Gold Standard” for performance, safety, and quality.
- **Legendary Customer Service** – Marco's legendary customer service team is staffed by friendly, highly-trained individuals who are focused on providing the highest level of product support, order accuracy, and customer satisfaction.
- **Product Availability** – We stock over 10,000 SKU's and have over 45 shipping locations to serve North American and International markets for all major brands of blasting and painting equipment. As the largest provider of surface preparation and protective coatings equipment in the world, our inventory levels and product availability are unmatched.
- **Logistics Services** – Marco's in-house logistics team is dedicated to moving your shipment anywhere in the world. We move over 14,000 truckloads every year, allowing you to save on freight costs by leveraging our buying power. Lower your process costs with a single invoice, which includes product and freight.
- **Technology Leadership** – Our website provides: Operator's Manuals, Part Numbers and Schematics Guides, MSDS information, and Features and Specifications Guides, providing access to information 24/7. Our Extranet application allows you to receive quotes and place orders online. Our Intranet maintains a complete record of your purchase history to assist with ongoing support of your existing equipment and future purchasing decisions.

Vision Statement

Marco is the world's premier provider of Abrasives, Blasting Equipment, Coating Equipment, Engineered Systems, Rental Equipment, Safety Equipment, Service, and Repair.

Mission Statement

Marco provides strong leadership and innovation to the surface preparation and protective coatings industries. We dedicate our efforts to the continuous improvement of our products, services, processes, people, and most importantly, the quality of our customer's experience.

Quality Policy

Marco is committed to providing superior quality in the design, manufacturing, distribution, rental, service, and repair of our products. Our ISO 9001:2008 certification extends throughout all operations in all locations. Continuous improvement of our processes and supply chain Integration comprise the core of our business strategy for delivering exceptional quality and value in all Marco products and services.



Management Philosophy

We are a company dedicated to the success of every customer and associate. We discuss, debate, challenge, measure, and test our ideas. We will be boundless and limitless in our passion to improve. Through sound leadership and dedicated associates, we will ensure a long term, profitable future for Marco, our associates, customers, and suppliers.

TABLE OF CONTENTS

Table of Contents	3
Graco® Contractor Airless Spray Guns	4-15
Graco® Contractor Airless Spray Guns Part Numbers.....	4
Part Numbers and Schematics	5
Tip Specifications.....	6
Tip Guards.....	7
Graco Tips Charts and Specifications	8-14
RAC® 5 SwitchTips™	8
RAC® 5 SwitchTips™ LineLazer™	9
RAC X™ Fine Finish SwitchTips™	10
RAC X™ SwitchTips™	11
Contractor Flat Tips	12
Silver Flat Tips	13
Fine Finish Flat Tips	14
Optional Accessories	15-16
Tip Gaskets.....	15
Tip Extensions	15
Tip Filter Housing.....	16
Tip Filters.....	16
Tip Brushes.....	16
Maintenance Notes	17-19

PART NUMBERS AND SCHEMATICS GUIDE

GRACO® CONTRACTOR AIRLESS SPRAY GUNS					
	Part Numbers	Trigger Style	Tip	Tip Guard	Maximum Working Pressure
	20G288421	2-Finger	RAC® 5 515	RAC® 5	3,600 psi
	20G288420	2-Finger	RAC® X 517	RAC® X	3,600 psi
	20G288425	4-Finger	RAC® X 517	RAC® X	3,600 psi

PART NUMBERS AND SCHEMATICS GUIDE



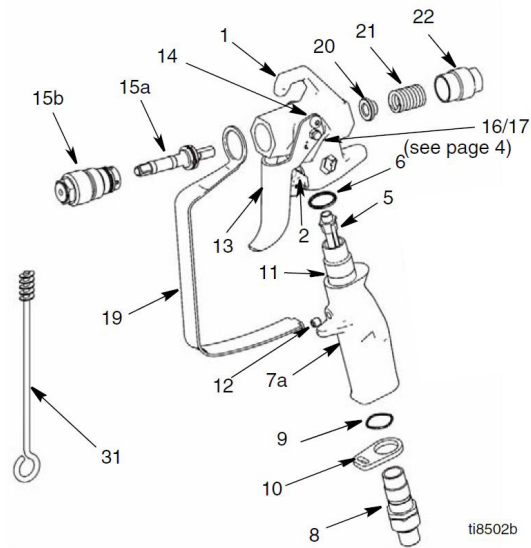



Figure 1: Graco® Contractor Airless Spray Guns











Item#	Part#	Description
Fig. 1		
1	20G288812	Housing Assembly
5	20G287032	Filter, 60 Mesh
	20G287033	Filter, 100 Mesh
	20G287034	Filter, 60 and 100 Mesh Combo
6	20G120777	Packing, O-Ring
7a	20G15K282	Handle
8	20G288811	Swivel Assembly
9	20G120733	O-Ring, Urethane, Clear
10	20G15J706	Retainer, Guard, Trigger
11	20G15J698	Tube, Handle
12	20G120834	Screw, Set
13	20G15J409	Trigger, 2-Finger
	20G15J768	Trigger, 4-Finger (not shown)
14	20G117602	Screw, Shoulder Pan HD
15	20G288488	Kit, Needle Repair
15a		Needle Assembly
15b		Diffuser Assembly
16	20G15J696	Pin, trigger
17	20G105334	Nut, Lock Hex
19	20G15J464	Guard, Trigger
20	20G15J528	Guide, Spring
21	20G121093	Spring, Compression
22	20G15B549	Nut, End
31	20G119799	Brush, Cleaning
—	206M510	Part Numbers and Schematics Guide – Graco® Contractor Airless Spray Guns
—	109V510	Operator's Manual – Graco® Contractor Airless Spray Guns

*Item not available for individual sale

PART NUMBERS AND SCHEMATICS GUIDE

		TIP SPECIFICATION SUMMARY				
Part Numbers	Tip Guard	Maximum Working Pressure	Color	Typical Applications	Typical Materials	
	RAC® 5 SwitchTip™ (20G286xxx)	RAC® 5 HandTite™ 20G243161 or 20G243263	4050 psi	Black	Residential, Commercial, or Industrial	Lacquers to Mastics, Latex Paints
	RAC® 5 SwitchTip™ LineLazer™ (20GLL5xxx)	RAC® 5 HandTite 20G243161 or 20G243263	4050 psi	Yellow	Parking Lots, Roads, Warehouse Floors, Crosswalks, and Athletic Fields	Heavy Waterbase to thin Alkyd Traffic Paints
	RAC® X Fine Finish SwitchTip™ (20GFFTxxx)	RAC® X HandTite 20G246215	4050 psi	Green	Cabinetry, Woodworking, Metal and Fine Finish Surfaces	Lacquers, Varnishes, Urethanes
	RAC® X™ SwitchTip™ (20GLTXxxx)	RAC® X HandTite 20G246215 or 20G246437	4050 psi	Blue	Residential, Commercial, or Industrial	Lacquers to Mastics, Latex Paints
	Contractor™ Flat Tip (20G269xxx)	Flat 20G220255 or 20G220251	5000 psi	N/A	Residential, Commercial, or Industrial	Architectural Coatings
	Silver Flat Tip (20G163xxx)	Flat 20G220255 or 20G220251	5000 psi	N/A	Residential, Commercial, or Industrial	Dyes, Ink, Stains, Oils, Auto Finishes
	Fine Finish Flat Tip (20G163xxx)	Fine Finish 20G220249	4050 psi	N/A	Cabinetry, Wood- working, Metal and Fine Finish Surfaces	Lacquers, Varnishes, Urethanes, and other Fine Finish Materials

PART NUMBERS AND SCHEMATICS GUIDE

		TIP GUARD SUMMARY		
Part Numbers		Tip Style	Thread Size	Color
	20G243161	RAC® 5 HandTite™	7/8 Inch	Orange
	20G243263	RAC® 5 HandTite	11/16 Inch	Orange
	20G246215	RAC® X™ HandTite	7/8 Inch	Blue
	20G246437	RAC® X™ HandTite	11/16 Inch	Blue
	20G220251	Flat	7/8 Inch	Orange
	20G220255	Flat	11/16 Inch	Orange
	20G220247	Fine Finish Flat	7/8 Inch	Orange
	20G220249	Fine Finish Flat	11/16 Inch	Orange

PART NUMBERS AND SCHEMATICS GUIDE

RAC® 5 SWITCHTIP™ SPECIFICATIONS

	Part Numbers	Tip Guard	Maximum Working Pressure	Color	Typical Applications	Typical Materials
	RAC® 5 SwitchTip™ (20G286xxx)	RAC® 5 HandTite™ 20G243161 or 20G243263	4050 psi	Black	Residential, Commercial, or Industrial	Lacquers to Mastics, Latex Paints

RAC 5 SwitchTips (20G286xxx)

		ORIFICE SIZE – INCHES																					
		.007	.009	.011	.013	.015	.017	.019	.021	.023	.025	.027	.029	.031	.033	.035	.039	.043	.045	.051	.055	.063	.065
FAN WIDTH	IN																						
	2-4		109	111	113	115		119	121														
	4-6	207	209	211	213	215	217	219	221	223	225					235							
	6-8	307	309	311	313	315	317	319	321	323	325	327		331									
	8-10		409	411	413	415	417	419	421	423	425	427	429		433	435	439	443		451	455		
	10-12		509	511	513	515	517	519	521	523	525	527	529	531	533	535		543		551	561	563	
	12-14		609	611	613	615	617	619	621	623	625	627	629	631	633	635		645		655			665
	14-16								721	723	725		729			735							
	16-18					815	817	819	821			827		831	833	835							
	18-20						917									935							
	Flow Rate (gpm)	.05	.09	.12	.18	.24	.31	.38	.47	.57	.67	.77	.90	1.03	1.17	1.31	1.63	1.98	2.17	2.79	3.25	4.26	4.53

PART NUMBERS AND SCHEMATICS GUIDE

RAC® 5 LINELAZER SWITCHTIP™ SPECIFICATIONS

	Part Numbers	Tip Guard	Maximum Working Pressure	Color	Typical Applications	Typical Materials
	RAC® 5 SwitchTip™ LineLazer™ (20GLL5xxx)	RAC® 5 HandTite™ 20G243161 or 20G243263	4050 psi	Yellow	Parking Lots, Roads, Warehouse Floors, Crosswalks, and Athletic Fields	Heavy Waterbase to thin Alkyd Traffic Paints

RAC 5 LineLazer SwitchTips (20GLL5xxx)

		ORIFICE SIZE – INCHES													
		.013	.015	.017	.019	.021	.023	.025	.027	.029	.031	.033	.035	.039	.055
FAN WIDTH	IN														
	2	213	215	217	219										
	4		315	317	319	321	323	325	327	329	331	333	335		355
	4-8			417	419	421	423	425	427	429	431		435		
	8-12					621	623	625	627	629	631		635	639	
	Flow Rate (gpm)	.18	.24	.31	.38	.47	.57	.67	.77	.90	1.03	1.17	1.31	1.63	3.25

PART NUMBERS AND SCHEMATICS GUIDE

RAC® X FINE FINISH SWITCHTIP™ SPECIFICATIONS

	Part Numbers	Tip Guard	Maximum Working Pressure	Color	Typical Applications	Typical Materials
	RAC® X Fine Finish SwitchTip™ (20GFFTxxx)	RAC® X HandTite™ 20G246215	4050 psi	Green	Cabinetry, Woodworking, Metal and Fine Finish Surfaces	Lacquers, Varnishes, Urethanes

RAC™ X Fine Finish SwitchTips™ (20GFFTxxx)

		ORIFICE SIZE – INCHES				
		IN	.008	.010	.012	.014
FAN WIDTH	2-4		108	110	112	
	4-6		208	210	212	214
	6-8		308	310	312	314
	8-10			410	412	414
	10-12			510	512	514
	12-14				612	614
	Flow Rate (gpm)		.07	.11	.15	.21

PART NUMBERS AND SCHEMATICS GUIDE

RAC® X SWITCHTIP™ SPECIFICATIONS

Part Numbers	Tip Guard	Maximum Working Pressure	Color	Typical Applications	Typical Materials
 RAC® X SwitchTip™ (20GLTXxxx)	RAC® X HandTite™ 20G246215 or 20G246437	4050 psi	Blue	Residential, Commercial, or Industrial	Lacquers to Mastics, Latex Paints

RAC™ X SwitchTips™ (20GLTXxxx)

		ORIFICE SIZE – INCHES													
		IN	.007	.009	.011	.013	.015	.017	.019	.021	.023	.025	.027	.029	.031
FAN WIDTH	2-4			109	111		115								
	4-6	207	209	211	213	215	217	219	221		225	227			231
	6-8		309	311	313	315	317	319	321	323	325	327	329		331
	8-10		409	411	413	415	417	419	421	423	425	427	429		431
	10-12		509	511	513	515	517	519	521	523	525	527	529		531
	12-14			611	613	615	617	619	621	623	625	627	629		631
	14-16									721	723			729	
	16-18						817	819	821				827		831
	Flow Rate (gpm)		.05	.09	.12	.18	.24	.31	.38	.47	.57	.67	.77	.90	1.03

RAC® X SwitchTips™ (20GLTXxxx) continued

		ORIFICE SIZE – INCHES												
		IN	.033	.035	.037	.039	.041	.043	.045	.051	.055	.061	.065	.071
FAN WIDTH	2-4													
	4-6			235										
	6-8			335										
	8-10	433	435		439	441	443	445	451	455				
	10-12	533	535	537	539	541	543	545	551	555	561			
	12-14	633	635	637	639	641	643	645	651	655	661	665	671	
	14-16		735											
	16-18	833	835											
	Flow Rate (gpm)		1.17	1.31	1.47	1.63	1.8	1.98	2.17	2.79	3.25	4.0	4.53	5.41

PART NUMBERS AND SCHEMATICS GUIDE

CONTRACTOR™ FLAT TIP SPECIFICATIONS

	Part Numbers	Tip Guard	Maximum Working Pressure	Color	Typical Applications	Typical Materials
	Contractor™ Flat Tip (20G269xxx)	Flat 20G220255 or 20G220251	5000 psi	N/A	Residential, Commercial, or Industrial	Architectural Coatings

Contractor™ Flat Tips (20G269xxx)

		ORIFICE SIZE – INCHES												
		IN	.011	.013	.015	.017	.019	.021	.023	.025	.027	.029	.031	.035
FAN WIDTH	4-6		211	213	215	217	219			225	227			
	6-8		311	313	315	317	319	321	323	325	327			
	8-10		411	413	415	417	419	421	423	425	427			435
	10-12		511	513	515	517	519	521	523	525	527		531	
	12-14			613	615	617	619	621	623	625	627		631	635
	14-16				715	717	719	721		725				
	16-18				815		819	821			827	829	831	
	18-20									925				
	Flow Rate (gpm)		.12	.18	.24	.31	.38	.47	.57	.67	.74	.90	1.03	1.31

PART NUMBERS AND SCHEMATICS GUIDE

SILVER FLAT TIP SPECIFICATIONS

	Part Numbers	Tip Guard	Maximum Working Pressure	Color	Typical Applications	Typical Materials
	Silver Flat Tip (20G163xxx)	Flat 20G220255 or 20G220251	5000 psi	N/A	Residential, Commercial, or Industrial	Dyes, Ink, Stains, Oils, Auto Finishes

Silver Fine Finish Flat Tips (20G163xxx)

		ORIFICE SIZE – INCHES												
		IN	.011	.013	.015	.017	.019	.021	.023	.025	.027	.029	.031	.035
FAN WIDTH	4-6		211	213	215	217	219			225	227			
	6-8		311	313	315	317	319	321	323	325	327			
	8-10		411	413	415	417	419	421	423	425	427			435
	10-12		511	513	515	517	519	521	523	525	527		531	
	12-14			613	615	617	619	621	623	625	627		631	635
	14-16				715	717	719	721		725				
	16-18				815		819	821			827	829	831	
	18-20									925				
	Flow Rate (gpm)		.12	.18	.24	.31	.38	.47	.57	.67	.74	.90	1.03	1.31

PART NUMBERS AND SCHEMATICS GUIDE





FINE FINISH FLAT TIP SPECIFICATIONS





	Part Numbers	Tip Guard	Maximum Working Pressure	Color	Typical Applications	Typical Materials
	Fine Finish Flat Tip (20G163xxx)	Fine Finish 20G220249	4050 psi	N/A	Cabinetry, Woodworking, Metal and Fine Finish Surfaces	Lacquers, Varnishes, Urethanes, and other Fine Finish Materials

Fine Finish Flat Tips (20G163xxx)



		ORIFICE SIZE – INCHES													
FAN WIDTH	IN	.008	.010	.021	.014	.016	.018	.020	.022	.024	.026	.028	.030	.032	
	2-4	108	110												
	4-6	208	210	212	214	216	218			224				232	
	6-8		310	312	314	316	318	320	322	324					
	8-10	408	410	412	414	416	418	420		424	426	428	430	432	
	10-12		510	512	514	516	518	520	522	524	526	528	530		
	12-14		610	612	614	616	618	620	622	624	626	628			
	14-16			712	714	716	718				726				
	16-18				814	816	818	820	822	824	826	828		832	
	18-20			912	914		918		922	924	926				
	Flow Rate (gpm)	.07	.11	.15	.21	.27	.35	.43	.52	.62	.73	.84	.97	1.1	



PART NUMBERS AND SCHEMATICS GUIDE



		TIP GASKETS		
Part Numbers		Description	Material	Package Quantity
	20G166969	1/16 Inch Thin Tip Gasket	Nylon	One Each
	20G223373	1/16 Inch Thin Tip Gaskets	Nylon	25/Package
	20G162863	5/32 Inch Thick Tip Gasket	Nylon	One Each
	20G223374	5/32 Inch Thick Tip Gaskets	Nylon	25/Package

		TIP EXTENSIONS	
Part Numbers		Description	Package Quantity
	20G246294	Heavy-Duty 10 Inch Tip Extension	One Each
	20G246295	Heavy-Duty 15 Inch Tip Extension	One Each
	20G246296	Heavy-Duty 18 Inch Tip Extension	One Each
	20G246297	High Pressure 180° Swivel	One Each

PART NUMBERS AND SCHEMATICS GUIDE

		TIP FILTERS		
Part Numbers		Mesh Size	Color	Package Quantity
	20G287032	60 Mesh	Black	1/Package
	20G287033	100 Mesh	Blue	1/Package
	20G287034	60 Mesh and 100 Mesh	Black and Blue	1 Each/Package

		TIP FILTERS	
Part Numbers		Mesh Size	Package Quantity
	20G224455	50 Mesh	2/Package
	20G224456	100 Mesh	2/Package

		TIP BRUSHES	
Part Numbers		Size	Bristle Material
	20G101891	3/8 x 2-1/4 Inches	Nylon
	20G101892	5/8 x 2-1/4 Inches	Nylon
	20G119799	3/8 x 1 Inch	Nylon

MAINTENANCE NOTES

DATE	TYPE OF SERVICE	PART NUMBER

GLOBAL HEADQUARTERS

- 3425 East Locust Street
Davenport, IA 52803

ph: 800.BLAST.IT (800.252.7848)

ph: 563.324.2519

fax: 563.324.6258

GULF STATES HEADQUARTERS

- 701 East Boulevard
Deer Park, TX 77536

ph: 800.BLAST.IT (800.252.7848)

ph: 281.930.0905

fax: 281.542.0736

REGIONAL BRANCH OFFICES

- **Iowa**
Davenport
- **Louisiana**
Harvey
Lafayette
- **Ohio**
Youngstown
- **Texas**
Beaumont
Corpus Christi
Deer Park



Experience, Trust, Service

ABRASIVES

BLASTING

COATING

ENGINEERED SYSTEMS

RENTAL

SAFETY

SERVICE & REPAIR

40+ NATIONWIDE SHIPPING LOCATIONS

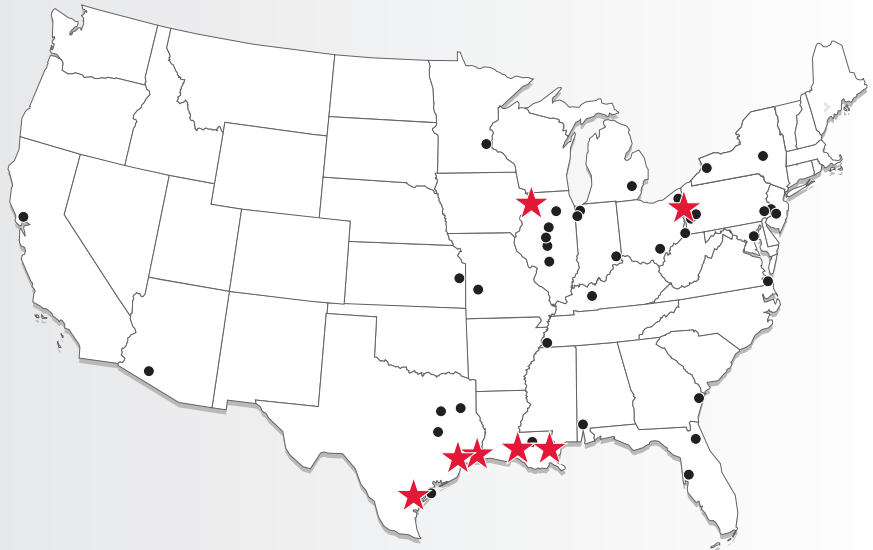

★ Marco Regional Branch Offices
and Shipping Locations

● Direct Shipping Locations

CONTACT MARCO

800.BLAST.IT

(800.252.7848)

563.324.2519

FAX: 563.324.6258

WWW.MARCO.US

SALES@MARCO.US